

The steering block (part #3) was left out for crating purposes. Assemble the steering block between the hoop (part #5) and plate (part #2) as shown in the diagram. Torque the mounting fasteners (part #4) to 16 ft-lbs.

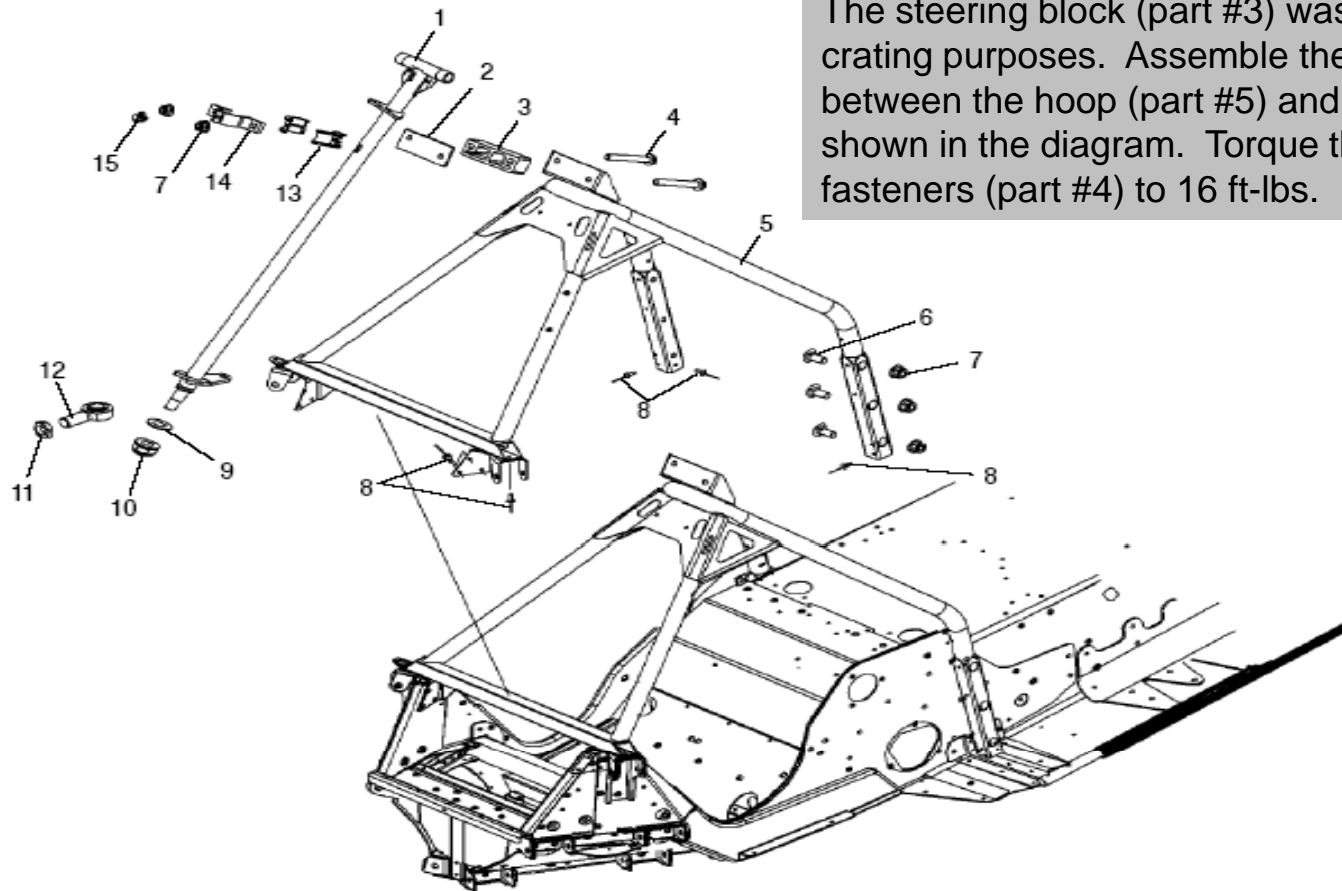

Part numbers may change after the making of the microfiche or paper copies. Electronic records are the most current.

Ref. Part No.	Qty.	Description
1	1	Post, Steering, Black
2	1	Plate, Steering Hoop
3	1	Block, Steering
4	2	Bolt
5	1	Hoop, Steering, Black
6	6	Bolt, Carriage
7	8	Nut, Flange
8	18	Rivet

Ref. Part No.	Qty.	Description
9	1	Washer, Thrust
10	1	Nut, Nylok
11	2	Nut, Jam
12	1	Rod End w/Bushing
13	2	Bushing
14	2	Bracket, Steering Post
15	1	Fitting, Zerk, 90 Degree